

TECHNICAL DATA SHEET

**Two Way Close-End
 Polyester coil
 Zip-fastener**

RT10 – ZTX



Raw Materials	
Chain	polyester monofilament
Tape	polyester yarn
Top Stop	aluminum
Bottom Stop	aluminum
Sliders	zinc alloy

Dimensions (1)		
Chain width	b	6,40 - 6,65 mm
Width of fastener	B	30,00 – 32,00 mm
Tape width	t	15,00 – 16,00 mm
Monofilament diameter	o	0,74 mm

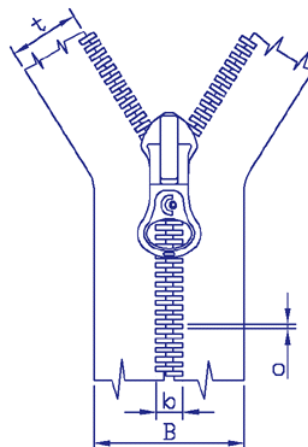

Functional properties (1)	
Slider moving force	< 6 N
Slider locking force	> 70 N

Mechanical properties (1)	
Lateral strength of fastener	> 600 N
Strength of closed end	> 55 N
Strength of top stop	> 80 N
Strength of puller attachment	> 150 N

Resistance to reciprocation (1)
Tearing strength of zippers tired with 300 tiring section (open-close) was not less then 90% of the standards without tiring.

Color fastness (2)		
Color fastness to light	7	MSZ 2102-2
Color fastness to washing 60 °C	5/5/5	MSZ EN 20105 CO 3
Color fastness to dry cleaning	5/5	MSZ 2104-1
Color fastness to perspiration (alkaline, acid)	5/5/5	MSZ 2105-4
Color fastness to dry/wet rubbing.	5/4-5	MSZ 2111-1

(1) According to the following standards: MSZ 8813/1, MSZ 8813/2, DIN 3417, DIN 3418, and DIN 3419-1. The tests were made by Concordia's own laboratory. The verification tests were made by ÉMI-TÜV SÜD Ltd.'s (KERMI) laboratory.

(2) Color fastness tests were made by ÉMI-TÜV SÜD Ltd.'s (KERMI) laboratory.

[•] Available sliders:

Automata nyitók

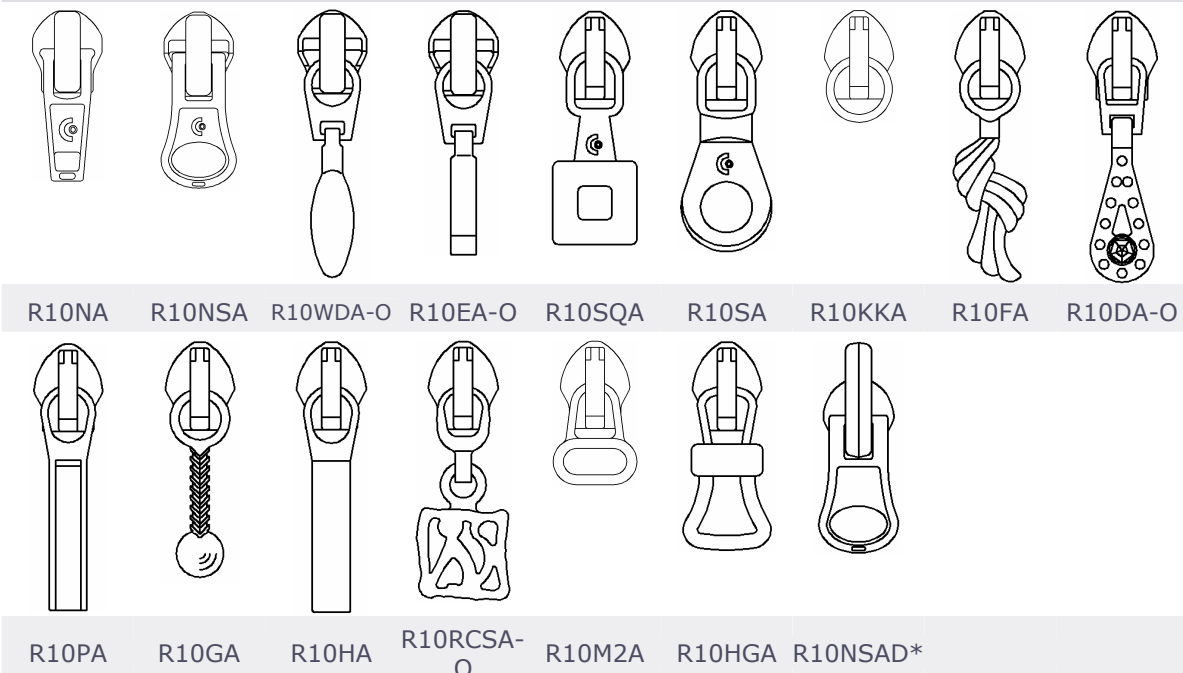

Laza nyitók

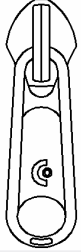

R10CL

*Reversible auto lock slider

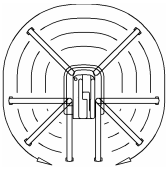

[•] **Human ecology information:** all of raw materials that were used under productions of this type of zip fastener and all of dyestuffs and textile chemicals were used to dyeing and finishing of this type of zip fastener are corresponding to the Oeko-Tex Standard 100 product class II. The nickel plated sliders are may unsafe – in case of direct skin contact – aspect of human ecology because of their nickel content.

[•] **Suggested applications:** bags, overalls, upholsteries, sleeping bags, sport accessories, sport equipment cases.

[•] **Handling requirements:**

